

EMCO

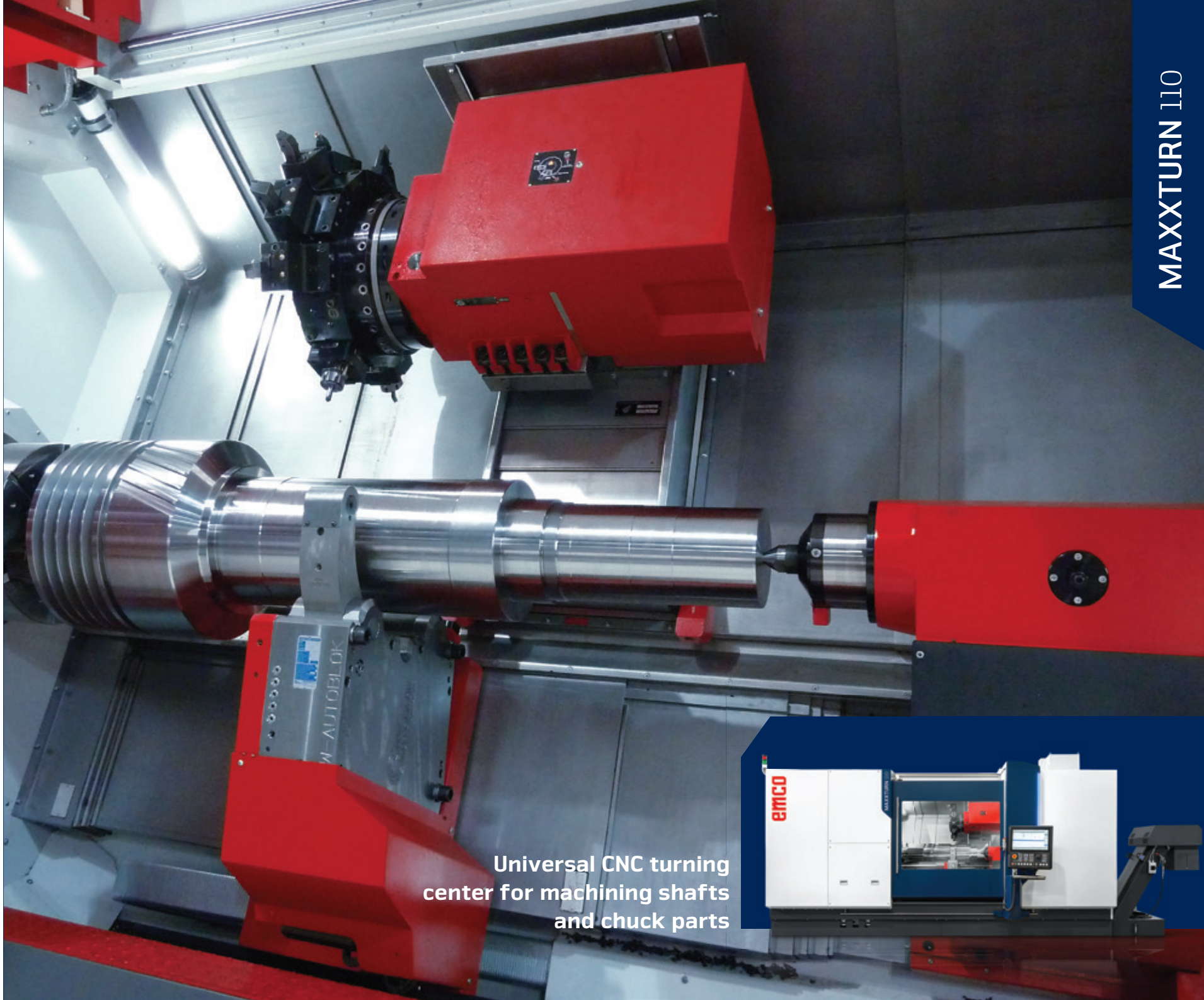

Universal CNC turning center for machining shafts and chuck parts



MAXXTURN 110

COMPLETE SOLUTIONS – NUMEROUS POSSIBILITIES

Maxxturn 110 is suitable for part lengths of up to 3500 mm and a turning diameter of 610 mm and can handle turning and milling operations involving heavy machining as perfectly as machining of precision parts with highest surface quality. A highly accurate C-axis, a stiff Y-axis with large movement path and high rapid traverses complete the performance package.

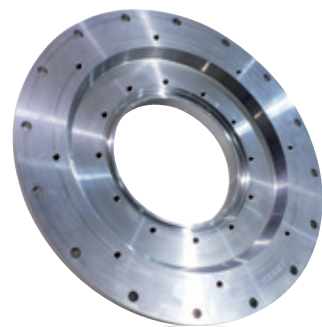

Adapter flange
(steel, CK45)

1 CONTROL UNIT

- / Ergonomic, pivotable and slidable control panel
- / Sinumerik with 22" color monitor
- / Comprehensive machining cycles
- / 3D simulation
- / USB interface, 230V power socket
- / EMCONNECT process control center

2 WORK AREA

- / 3 bed lengths
- / Optimum access with 60° inclined bed and machine design
- / Maximum flexibility with multiple turret concepts

3 MACHINE BED

- / Widely spaced guide ways
- / Large dimensioned roller-type guide ways
- / Highest solidity
- / Maximum pre-load guarantees rigidity in several cutting load directions

4 STEADY REST SYSTEM

- / Tag along steady rest in various sizes
- / Optional: NC steady rest or tandem steady rest
- / Easy to remove
- / Sealing air, cover and flushing included in the standard version
- / Optional: Programmable pressure setting



Machine with optional equipment

5 Y AXIS

- / Travel -80 / +100 mm (- 3.1 / +9.4")
- / 90° implemented in the machine construction
- / Large distance between guides
- / Stable and compact construction, without restrictions

6 CHIP CONVEYOR

- / Hinge type chip conveyor with ejection height of 1150 mm (45.3")
- / Suitable for: Long steel chips, swarf balls, wooly swarf, dry and wet machining
- / With integrated coolant unit
- / Easy to remove, easy to clean
- / Optional: High-pressure pumps

7 TAILSTOCK

- / Tag-along tailstock
- / Optional: NC tailstock
- / Integrated bearings for MT5 centering tip
- / Quill diameter \varnothing 150 mm (5.9")
- / Quill travel 150 mm (5.9")
- / Incl. position and pressure monitoring

8 MACHINE COVER

- / All-round protection against chips
- / 100% coolant retention
- / Large safety glass window in door
- / Clear view into the work area

STRUCTURE

With the aid of FEM analyses, the MAXXTURN 110 was optimally designed to meet the high demands of the modern machining world. The core of the machine is the one-piece machine bed. This is designed as a closed welded steel construction and filled with polymer concrete. Additional reinforcements ensure maximum stability in stressed areas. This guarantees maximum stiffness, precision and optimum vibration damping. The MAXXTURN 110 stands for a long service life and, at the same time, high machining accuracy. It is the basis for high added value in production.



1 TOOL TURRET

- / VDI quick change system
- / 12 driven tool stations
- / Block tool holders for internal machining
- / Swivel speed adjustable with override

2 MAIN SPINDLE

- / High drive power 42 / 33 kW
- / High holding torques for milling operations
- / Closed cooling circuit
- / Spindle connection A2-8
- / Partial hollow clamping $\varnothing 95 \times 670$ mm
- / Hollow clamping cylinder $\varnothing 95$ mm as an option

3 ROLLER GUIDES

- / In all linear axes
- / Preloaded
- / Backlash-free in all directions of force
- / High rapid traverse speed
- / Wear-free
- / Minimum lubrication required

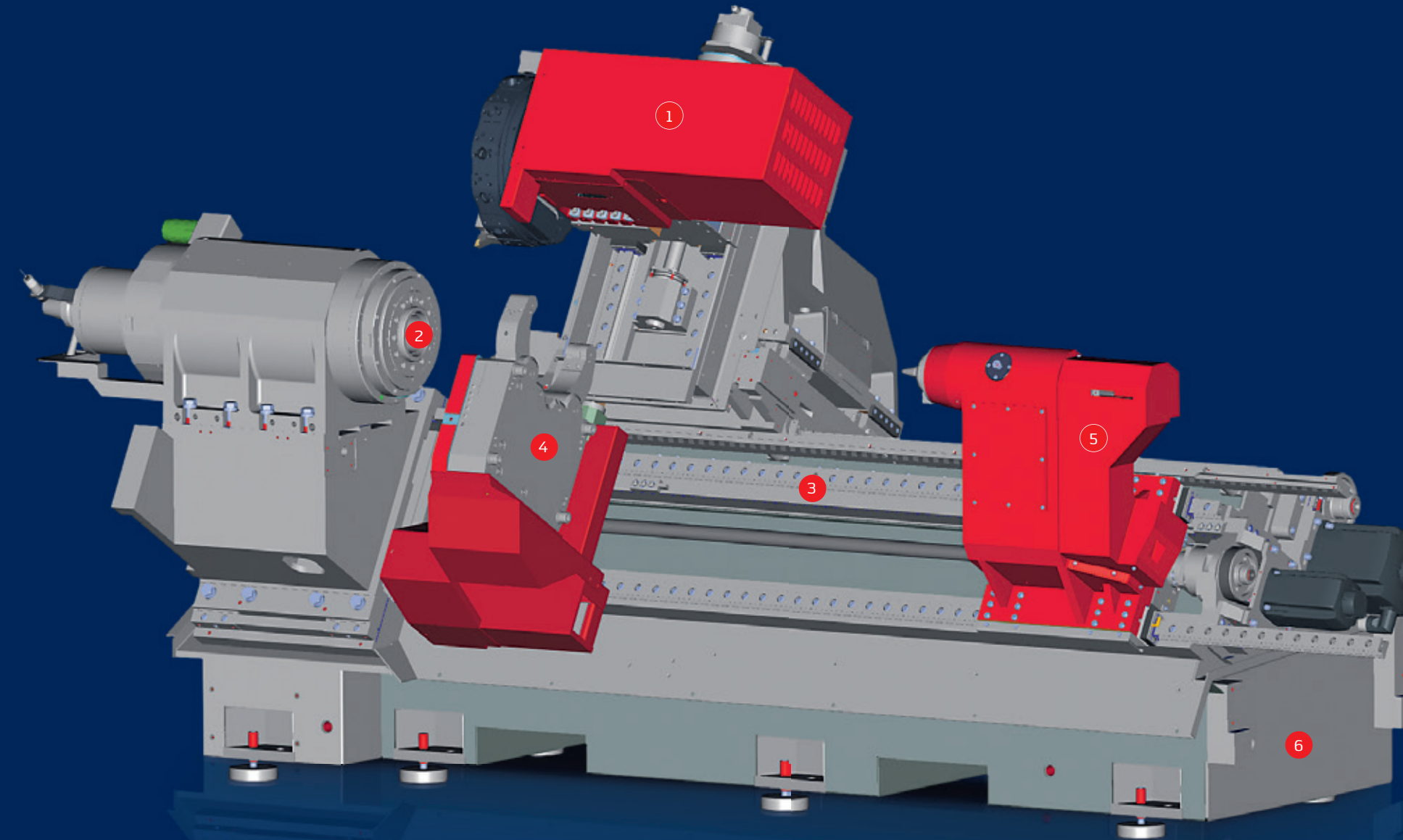

4 STEADY REST

- / Clamping range with various steady rest $\varnothing 20 - 420$ mm possible
- / Self centering
- / Automatic central lubrication, sealing air and roller flushing integrated
- / Trailed or NC-controlled

5 TAILSTOCK

- / Quill with integrated bearing for heavy machining processes
- / Quill diameter 150mm, stroke 150mm
- / Inner cone MTS, optional MT6 with quill diameter 180 and stroke 250 mm
- / Trailed or NC-controlled

6 MACHINE BED

- / Monobloc construction
- / Welded steel construction filled with polymer concrete

TECHNICAL HIGHLIGHTS

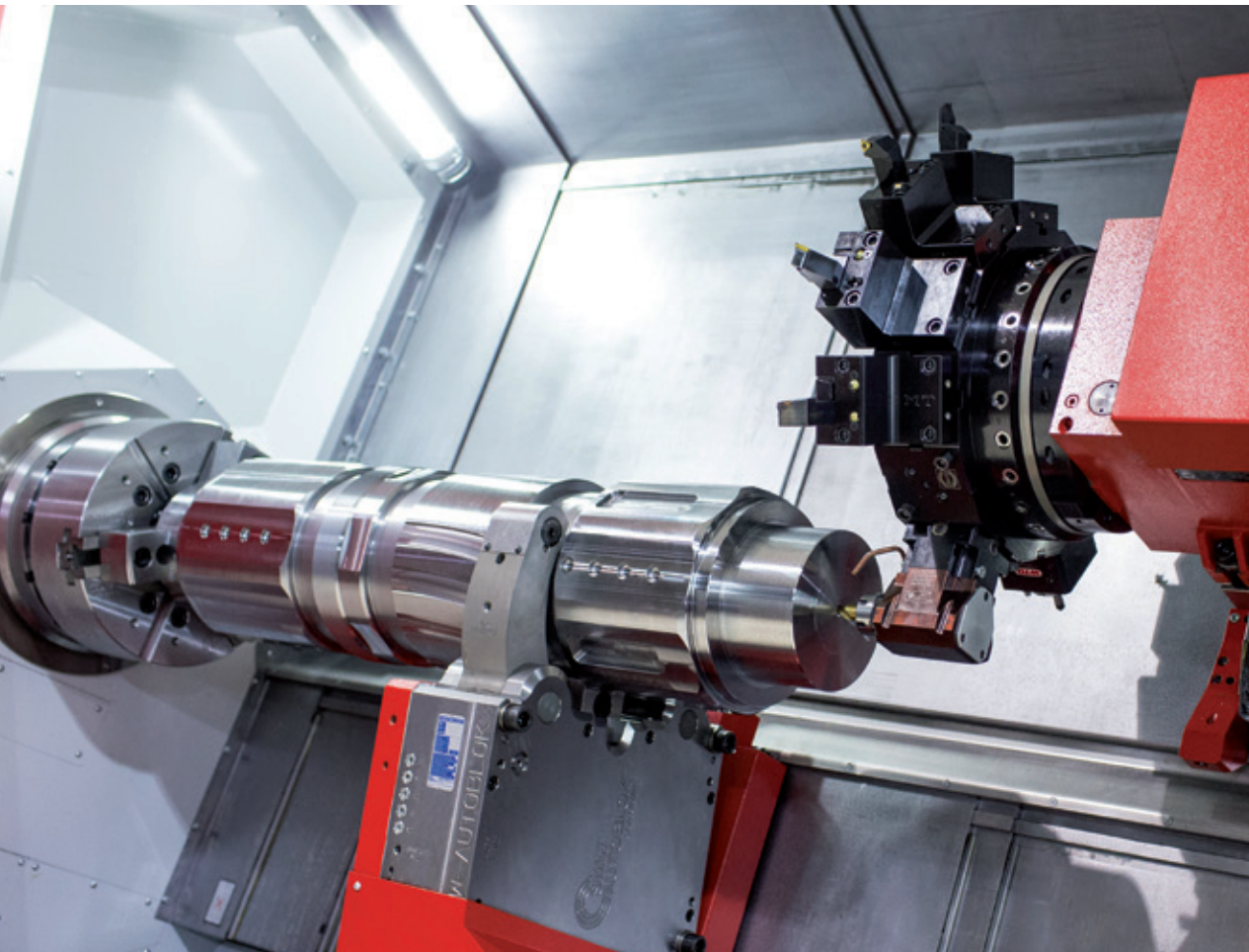

THE MAXXTURN SERIES

The Maxxturn series is designed as a modular system with expansion stages from simple turning operations to a turn-mill centre with different application potential: Dynamic integrated spindle motor as well as high torque implementations, direct drive turret with BMT or VDI tool holder systems.

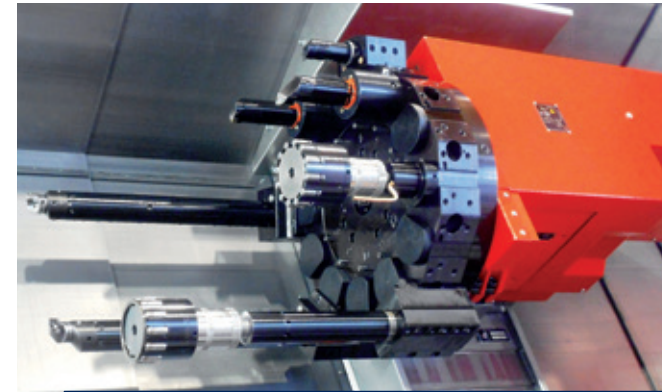

PROCESSING OPTIONS

On the MT110 with VDI50 and block-tools, process-optimised, short cylinder tube machining with a surface quality of RA 0.2 can be carried out using roller burnishing tools. An 80 bar band filter/coolant preparation increases the coolant volume as well as the quality and service life of the cooling lubricant.

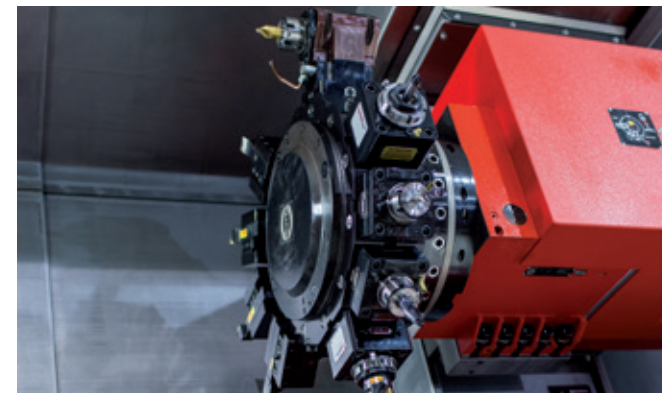

MT 110 BMT TURRET

For cost-effective production of complex turning/milling workpieces, in which milling is predominant, the optional BMT 65P turret with water-cooled direct drive is available. With a maximum of 6000 rpm, 45/62 Nm and 15/22 kW, this turret offers optimum conditions, stability for complete machining and maximum productivity.

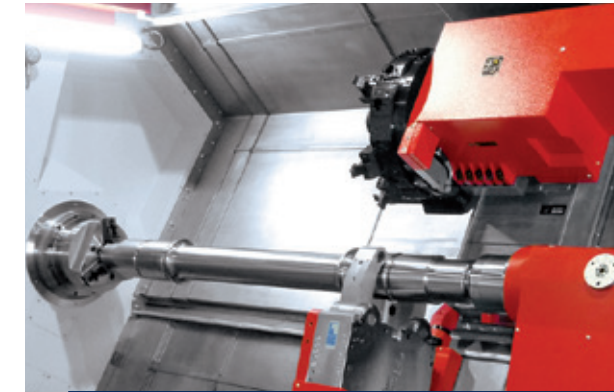

MACHINE CONCEPT

Best turning-milling for each machining. Robust and high-precision machine design to allow the complete realisation of long workpieces. The wider door opening, the automatic, stable tailstock with integrated storage and MT6 cone (option) and a swiveling control panel for optimal operation and uncompromising handling.



AUTOMATIC STEADY RESTS

Self-centering steady rest with hydraulic actuation. Built on the tailstock track and optionally movable over Z-slides movable with servo drive (NC-axis). Sealing air, central lubrication, flushing and integrated flushing channels on the arms (optional) are available for one or more steady rest units or slide systems.

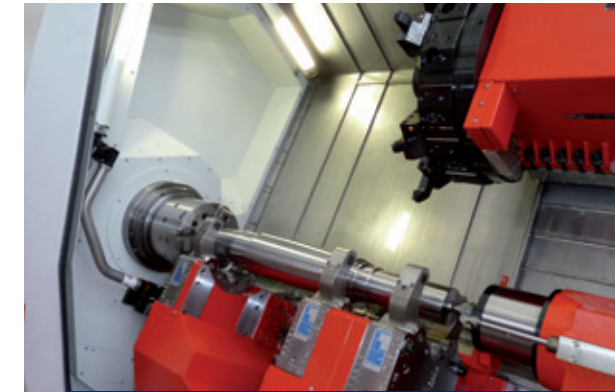

STEADY RESTS / CLAMPING

High-precision complete machining is possible with 3 steady rests on two process-driven slides. Optimal productivity with maximum flexibility is provided due to a shaft-chuck with retractable jaws carrier and face driver, as well as tool calibration.

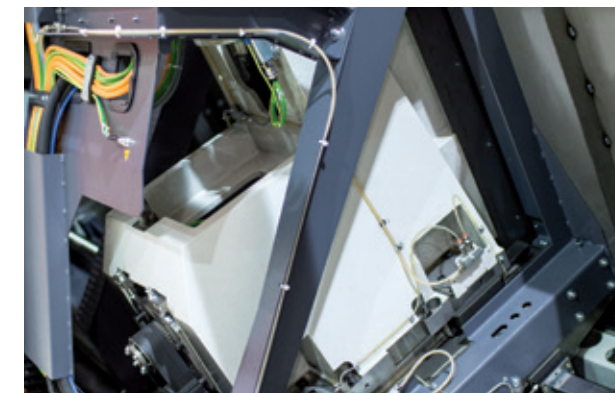

HIGH-PRECISION Y-AXIS

The Maxxturn machine concept has been specially developed for placement of the Y-axis at an angle of 90°. Due to large dimensioned, widely spaced and pre-loaded guide ways, the Y-axis offers optimal machining results with maximum stability and short overhangs.

HIGHLIGHTS

- / Extremely robust construction
- / Top machining precision
- / High rapid motion speed
- / Stable Y-axis with large travel (-80 / +100 mm (-3.1 / +3.9"))
- / Optional: NC steady rest or tailstock
- / Hydraulic spindle break
- / State-of-the-art control technology
- / Driven tools with C-axis
- / Simple, conversational programming
- / Made in the Heart of Europe

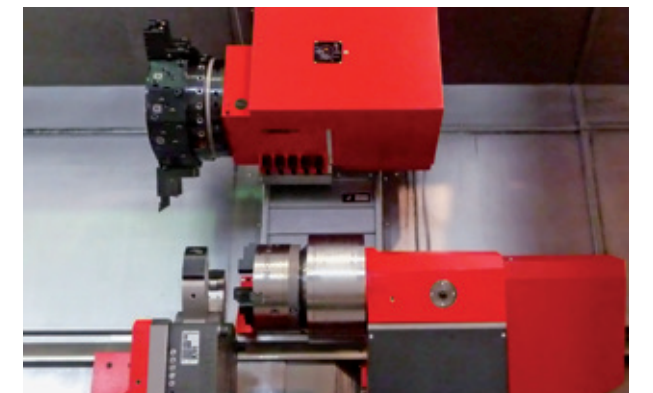

EMCO SPECIAL SOLUTIONS

The Emco expertise in engineering and solution is unique, economical and future-oriented. The standard tailstock is supplemented with a 3 jaw quick change power chuck to guide/support the customer's part more accurately and stably. Thanks to the quill, the jaw movement is 100% automatic with safe working conditions.

NETWORKS ARE CREATED INDIVIDUALLY – OUR SOLUTIONS AS WELL

Staying in touch is important not only among human beings. Persons, machines and the whole production environment must also be connected perfectly and safely in order to ensure efficient procedures during the production process. With EMCONNECT, the machine is optimally equipped for this purpose. The optional EMCONNECT Digital Services offer innovative online services for optimized machine operation. The user has always the control of the machine status. The automatic notification in case of malfunctions or standstill of the machine as well as the extended capabilities for remote maintenance, minimise downtimes.

Integration into control

EMCONNECT offers several possibilities of operation according to different situations. For quick access, apps may be used simultaneously in the side panel of controlling. In this way, you can always look at your familiar numerical control, the well-known centrepiece of the machine.

An innovative concept

These powerful apps may be used independently from the control, while in the background the machine is busy in the production process. With only one click, you can change at any moment between numerical control and EMCONNECT. This is possible with the help of an innovative and ergonomic control panel, equipped with a modern 22" multi-touch display, an industrial PC with associated keyboard and HMI hotkeys.



The control panel as central platform

With EMCONNECT, the control panel of the machine becomes the central platform for the access to all the operative functions. The user gets every type of support from the apps, which directly provide all the necessary applications, data and documents. In this way, EMCONNECT makes an important contribution to a highly efficient processing at the machine.



Comprehensive connectivity options

With the remote support, the web browser and the remote desktop, there are numerous connectivity options, even beyond the direct production environment. With the help of the integrated remote support, it is easily possible to carry out the remote diagnosis and remote maintenance. The optionally available OPC UA interface enables data exchange with the IT system environment and interaction with other machines for automation at shop floor level.

EMCONNECT HIGHLIGHTS AND FUNCTIONS

- / Fully connected**
Connection to all applications via remote control of the office computer and the web browser
- / Structured**
Clear monitoring of the machine state and the production data
- / Customized**
Open platform for modular integration of customer-specific applications
- / Compatible**
Interface for seamless integration into the operating environment
- / User-friendly**
Intuitive and production-optimized touch operation data
- / Future-proof**
Continuous extensions as well as easy updates and upgrades

Standard-Apps

Control	Dashboard
Machine Data	System
Remote Desktop	Web Browser
Remote Support	Settings
Cutting Calculator	Calculator
Notes	Service
Documents	EMCO TechSheet
GD&T	File Import
Shopfloor Data	Thread Reference
	Tricalc

Optional

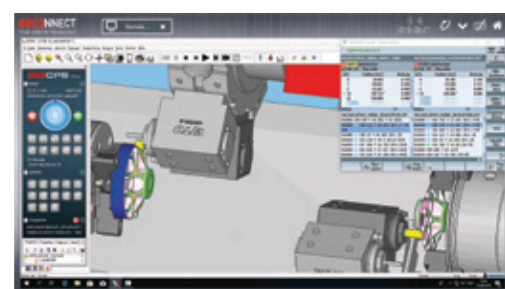
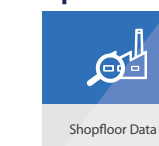

EMCO AUTOMATION SOLUTIONS: OPTIMIZATION OF PRODUCTION PROCESSES WITH HIGH-LEVEL FLEXIBILITY

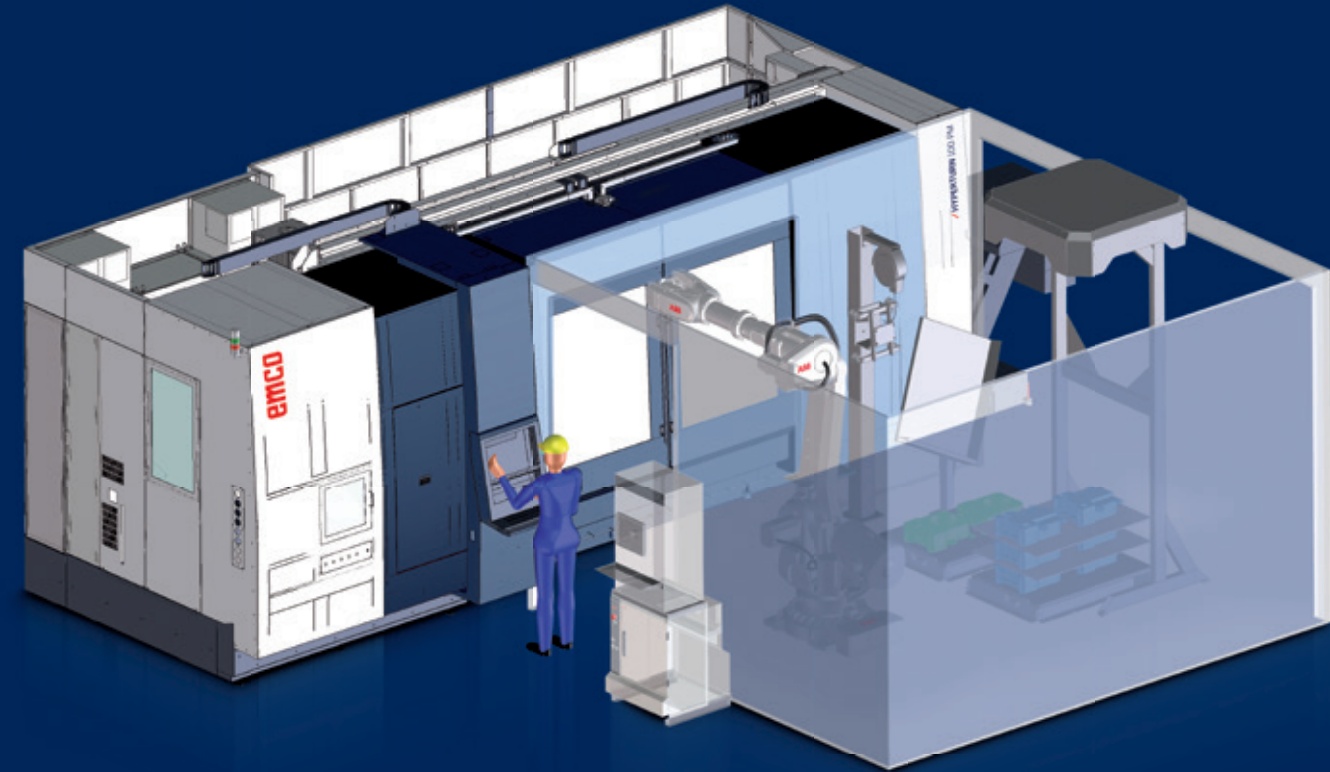

Concept possible for all machines

ADVANTAGES

- / Fully automatic loading and unloading of the workpieces
- / Multi-channel Sinumerik control incl. user cycles
- / Seamless interplay between the machine tool and the loading device
- / Varied possibilities of customer-specific adaptation
- / Possibility of integration of measuring station, signing station, cleaning station, etc.
- / Reduction of the set-up time due to a loading hatch
- / Worldwide service

NONSTOP RETURN ON INVESTMENT

EMCO solutions focus on customer-specific requirements.

The perfect implementation of customer-specific requirements shortens production times. The compact installation dimensions of 8900 x 7200 mm optimally match the conditions in production. The robot head change with different grippers, the flexible self-centering solution for different parts, the combination of parts by the tool turret and the B-axis expand the system and meet the demand for high productivity. Pallet-scanners for rough pieces enable oriented loading of the rough pieces into the machine and increase the autonomy for unattended production.



Automation concept example



In cooperation with ABB, the robot IRB6700 / 245 kg, the pallet system FLEXLOADER FP800 with 2D / 3D camera and the completion of the system from the baking station with automatic changeover are the basis for a perfect result that meets the customer's requirements.



The very short set-up times, the optimal software solution and the user-friendliness with highest safety are the decisive factors for a profitable production.

ACCURACY AND PRODUCTIVITY

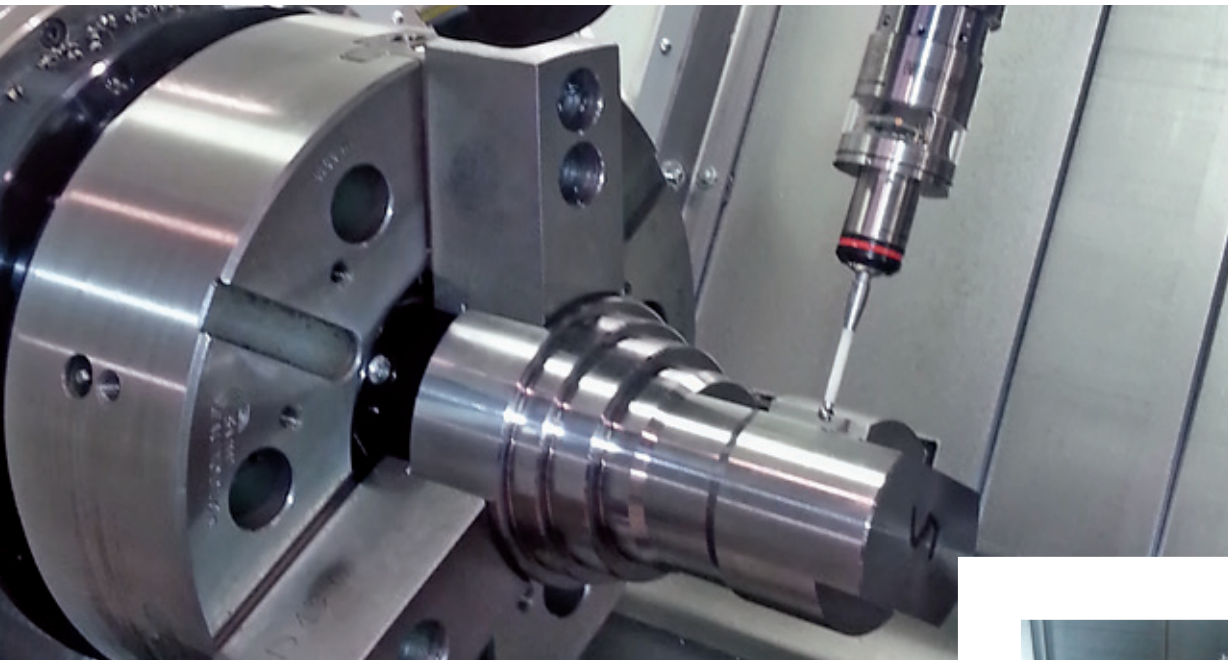

Positioning accuracy P in X	0,008 mm
Medium position variation range PS in X	0,0025 mm
Positioning accuracy P in Z*	0,010 mm
Medium position variation range PS in Z*	0,003 mm
Positioning accuracy P in Y	0,004 mm
Medium position variation range PS in Y	0,002 mm
Positioning accuracy P in C1*	0,03°
Medium position variation range PS in C1*	0,01°

*Bed length Z=1700, spindle connection A2-8"

Glass scale and laser measurement / lead error compensation have to be order optional

Measurement of positioning according to VDI / DGQ 3441
 Medium position variation range PS: Repeatability of positioning carriage (repeated starting up a point from the same direction).
 Positioning accuracy P: sum of the individual deviations = positioning scatter + hysteresis + positional deviation

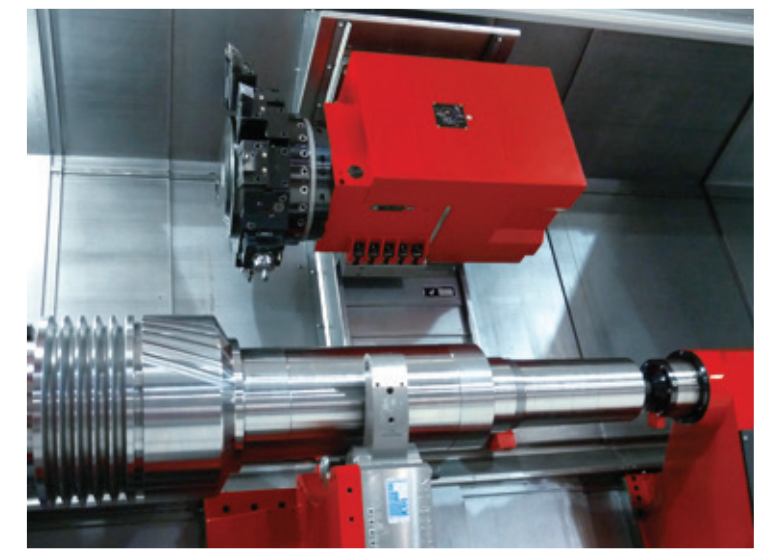

The probe is in the turret with radio transmission for scanning the workpieces and automatic transfer of values used by measuring cycles.

Feed Force	X / Y	Z			
kN	0,010 mm	20 (30 opt.)			
Removal rate (mat. CK45)	cm ³ /min	f (mm)	ap (mm)	Vc (m/min)	Dm (mm)
Turning	860	0,6	10	180	300
Milling	390	1,25	4	250	63
Drilling	425	0,15		250	120

SINUMERIK OPEN, STRONG, FLEXIBLE

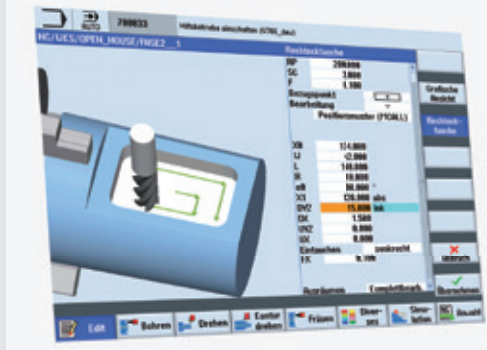

Shopturn - Shopmill / processing cycles

The machine programming can be freely selected from DIN to shop turn. Complex work pieces require efficient production methods and innovative CNC solutions. The CNC equipment SINUMERIK supports multi-technology machines in the machining of workpieces in one setting and offers for this purpose innovative functionality – even when alternating between different technologies.



Processing simulation

3D simulation during turning and milling, with detailed representation and workpiece profile. This achieves a significantly higher efficiency in production and all information is available on the machine.



Tool management

Simple and open operation through integrated tool management for all tool types and data.

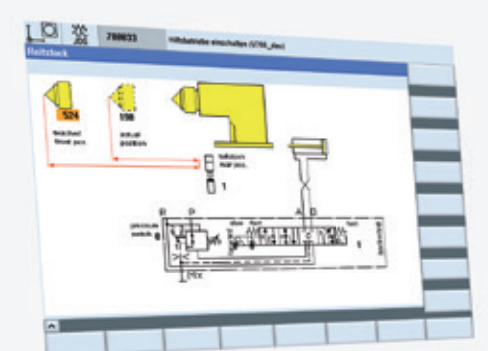

EMCO diagnostics

EMCO diagnostics for rapid, simple analysis of the entire machine (example: tailstock hydraulic diagram and sleeve position monitoring).

UNCOMPROMISING QUALITY FOR TOP PRECISION

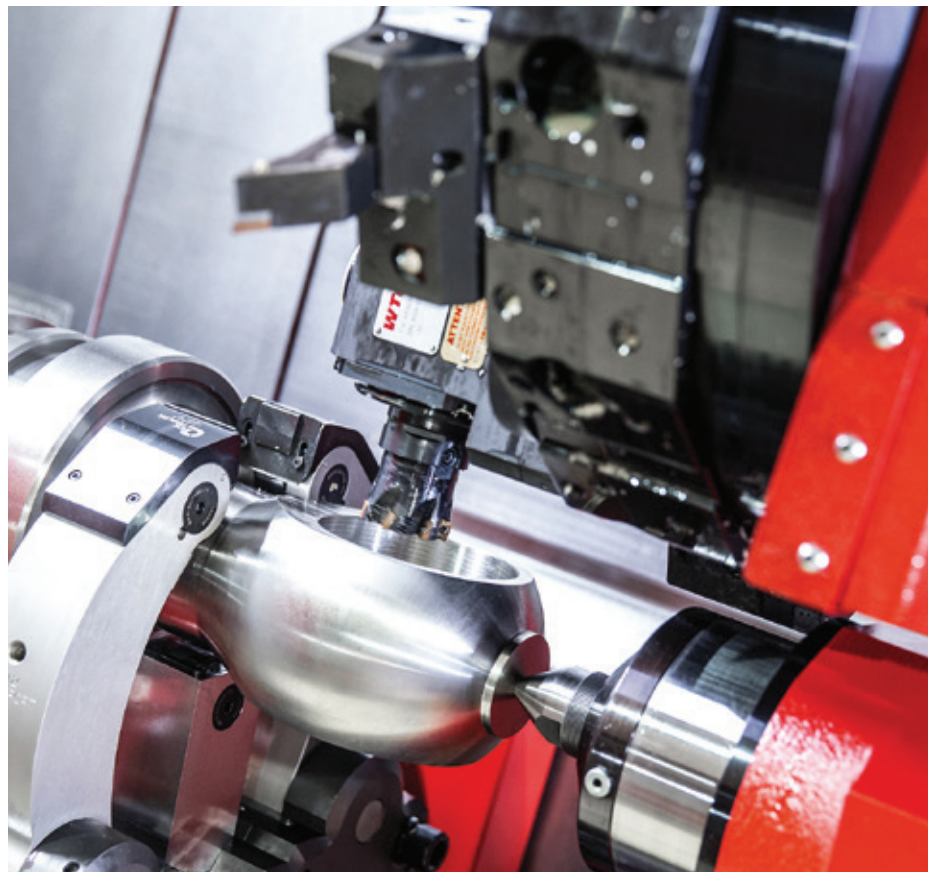

Due to the excellent Y-axis, milling operations can be performed easily and accurately.

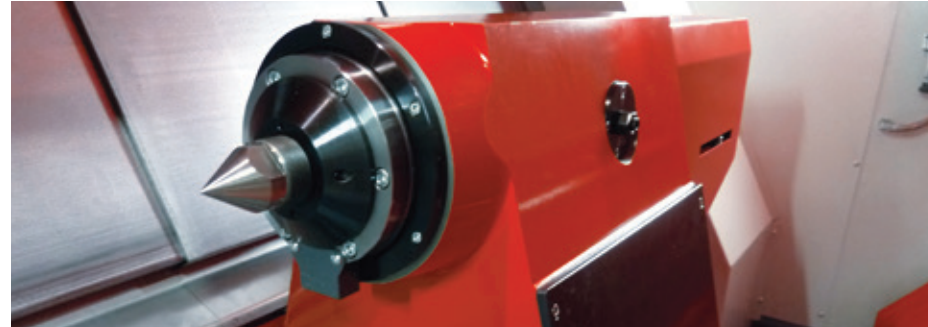

Tailstock with quill with MT5 or optionally with MT6 always with integrated bearing for stable process support.

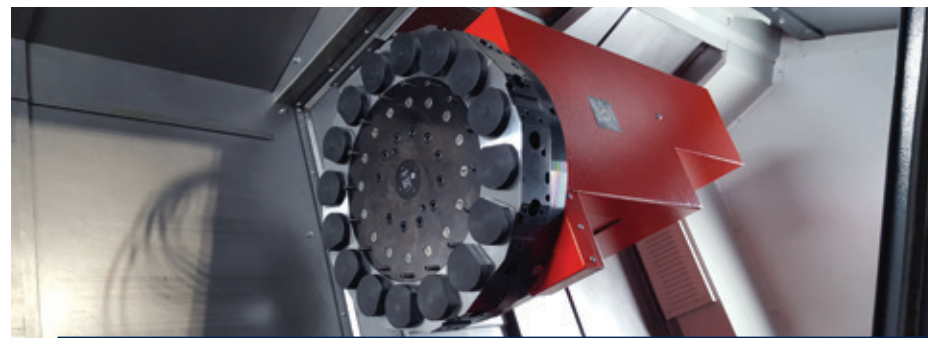

Tool turret can be optionally supplied with up to 16 positions and with various interfaces (VDI, BMT, CDI, Direct,...)

MODULAR MACHINE STRUCTURE

The heart of the machine is the 60° slanted machine base made of a top-quality, composite material consisting of special concrete and steel that provides numerous advantages over conventional materials. Compact monoblock construction for extreme stiffness and a stable base for the rest of the machine. The results are outstanding surface qualities, more narrow production tolerances and longer machine lifetimes. This means that the high drive performance of the work spindle can be used without restriction.

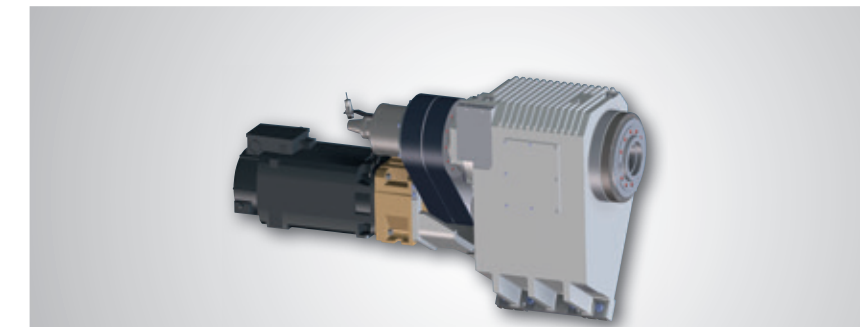

Main spindle A2-11 (A2-15)
(max. speed range: 2000 rpm)
(max. torque: 3400 Nm (2507.7 ft/lbs))

- Belt drive with two-speed transmission
- Maximum drive power: 52 kW (69.7 hp)
- Maximum torque: 2480 Nm (1829.15 ft/lbs)
- Maximum speed: 2500 rpm
- Partial hollow clamping:
ø 110 x 1000 mm (4.3 x 39.37")

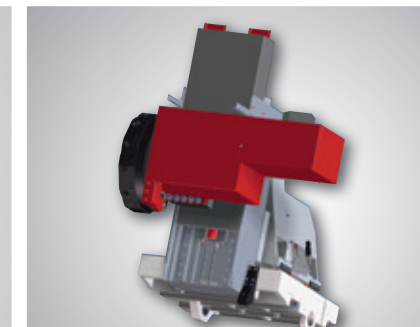

Tool slide with Y-axis (-80/+100) integrated as an extremely rigid element into the machine structure

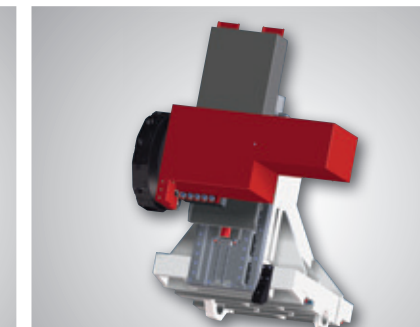

Tool slide without Y-axis

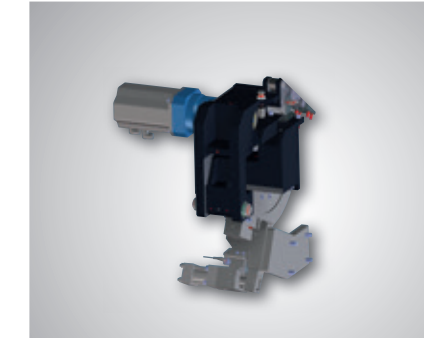

Retractable C-axis including hydraulic spindle brake

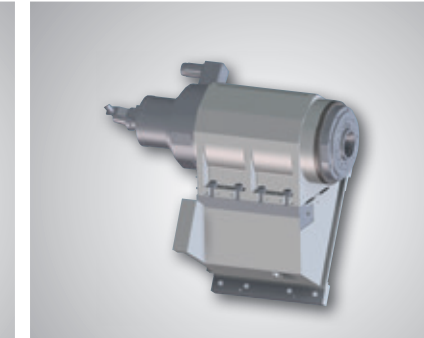

Main spindle A2-8

- Water-cooled spindle motor (ISM)
- Maximum drive power: 33 kW (44.2 hp)
- Maximum torque: 800 Nm (589.6 ft/lbs)
- Maximum speed: 3500 rpm
- Bar capacity: ø 95 mm (3.7")

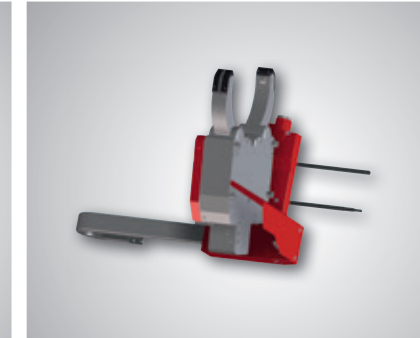

Self-centring schlepp-steady rest Dm. 11-152/35-250/45-310/100-410 as single or tandem version possible. NC-drive optional

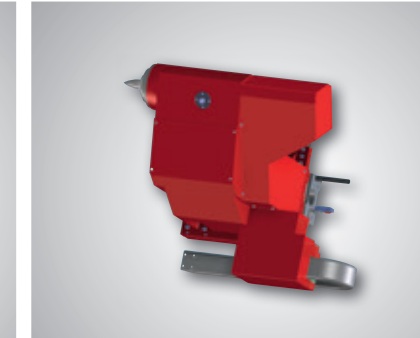

Large tailstock with quill and integrated bearings for stable shaft machining

POWER AND TORQUE

Alternatively, various standardised turret/spindle solutions are available: BMT or VDI, with 8"-, 9"- or 15"-serie spindles. Optimum performance and torque for any form of processing is achieved by precise coordination of mechanics and control.

POWER AND TORQUE

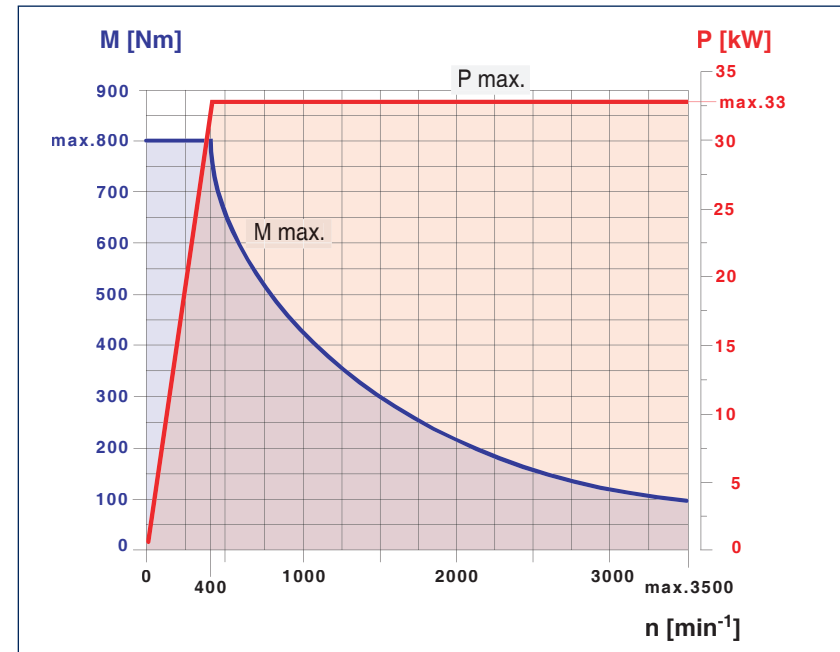

MT110 spindle characteristic A2-8"

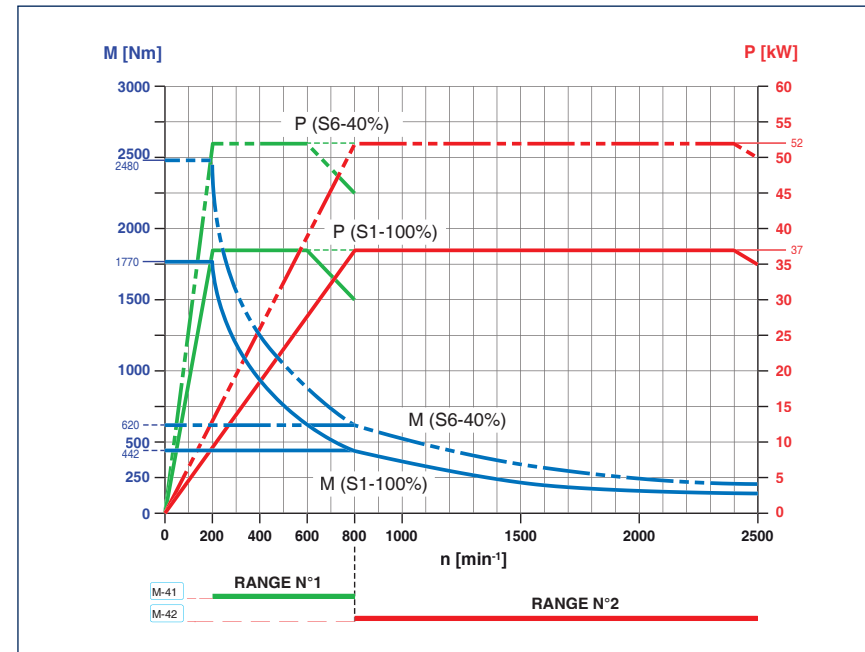

MT110 spindle characteristic A2-11"

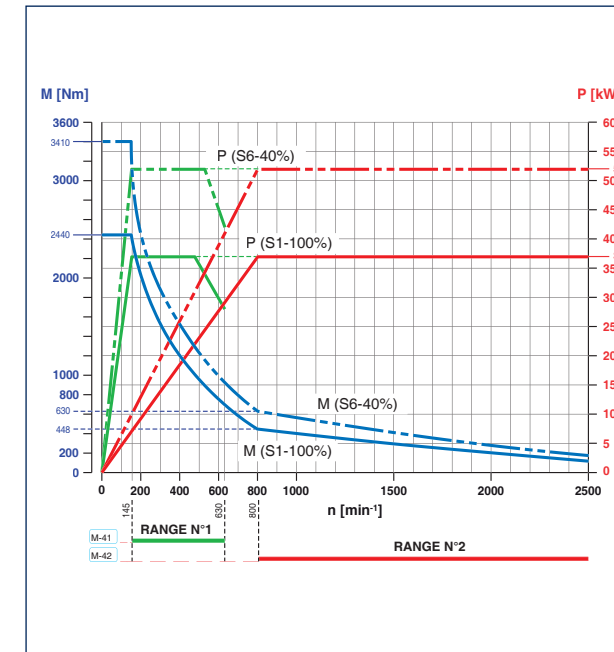

MT110 spindle characteristic A2-15"

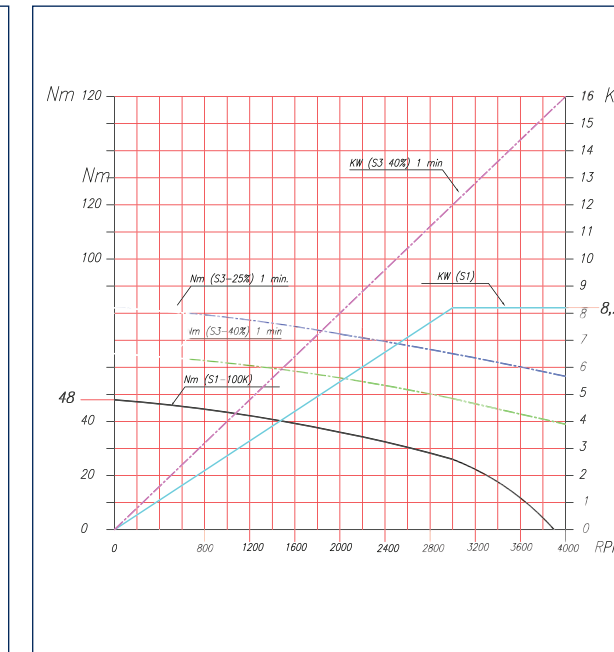

MT 110 turret characteristic VDI50

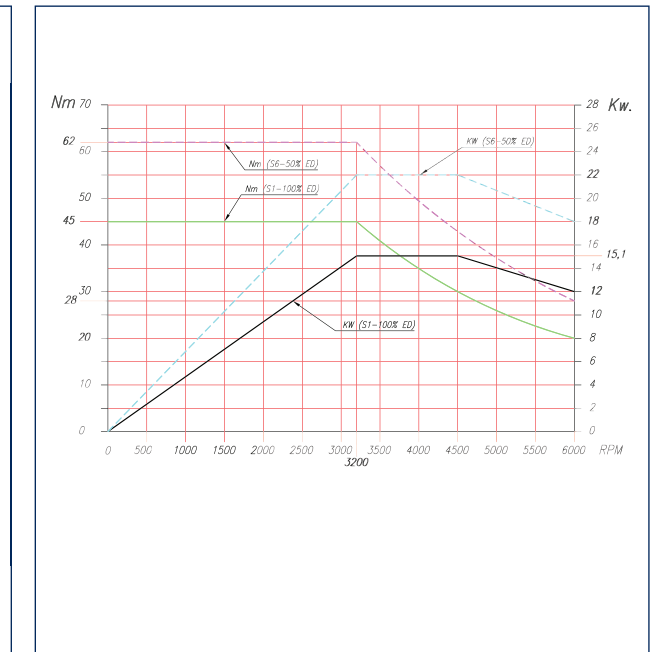

MT 110 turret characteristic BMT65P (opt.)

MACHINE LAYOUT

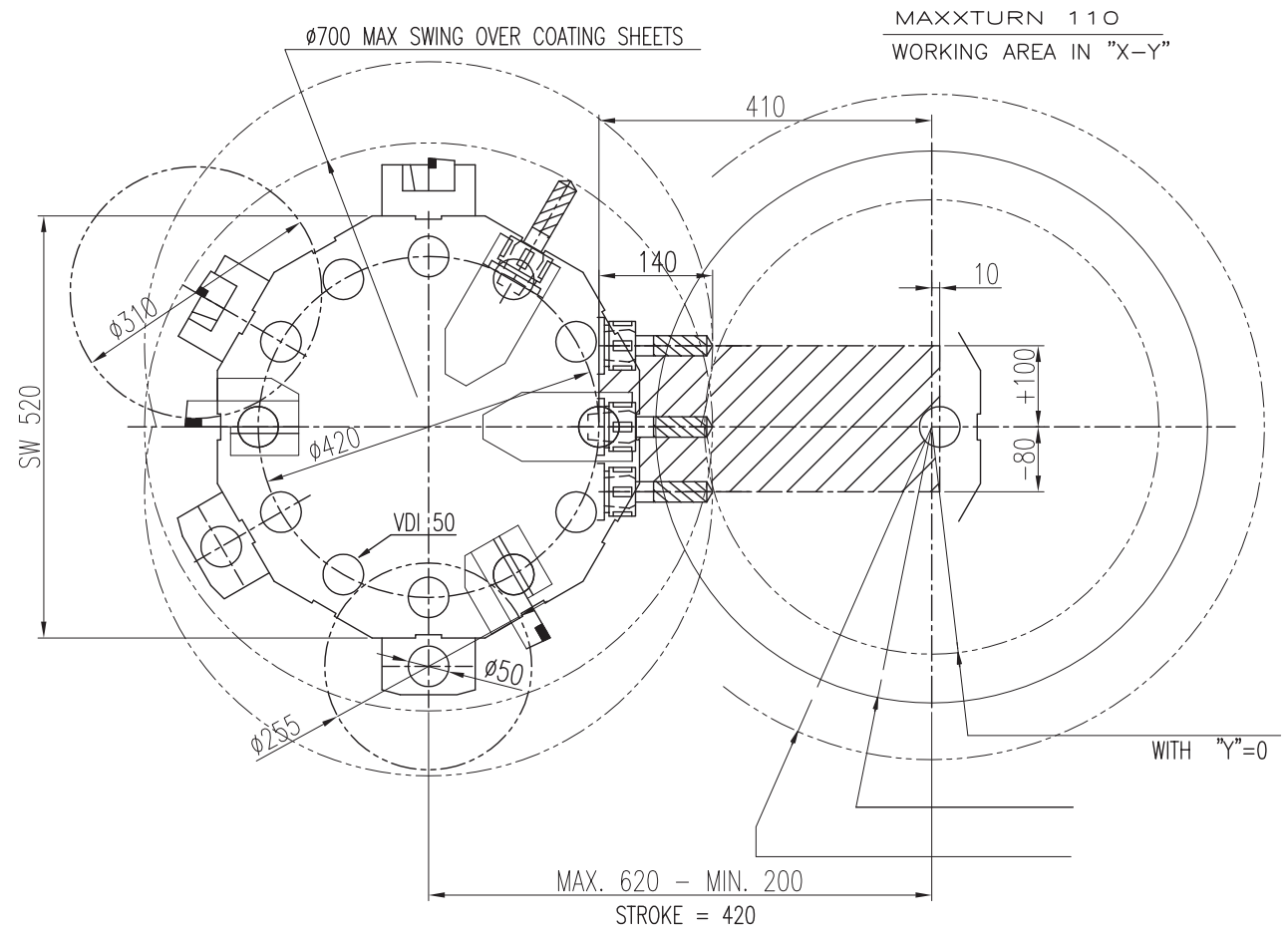

Indications in millimeters

MACHINE LAYOUT

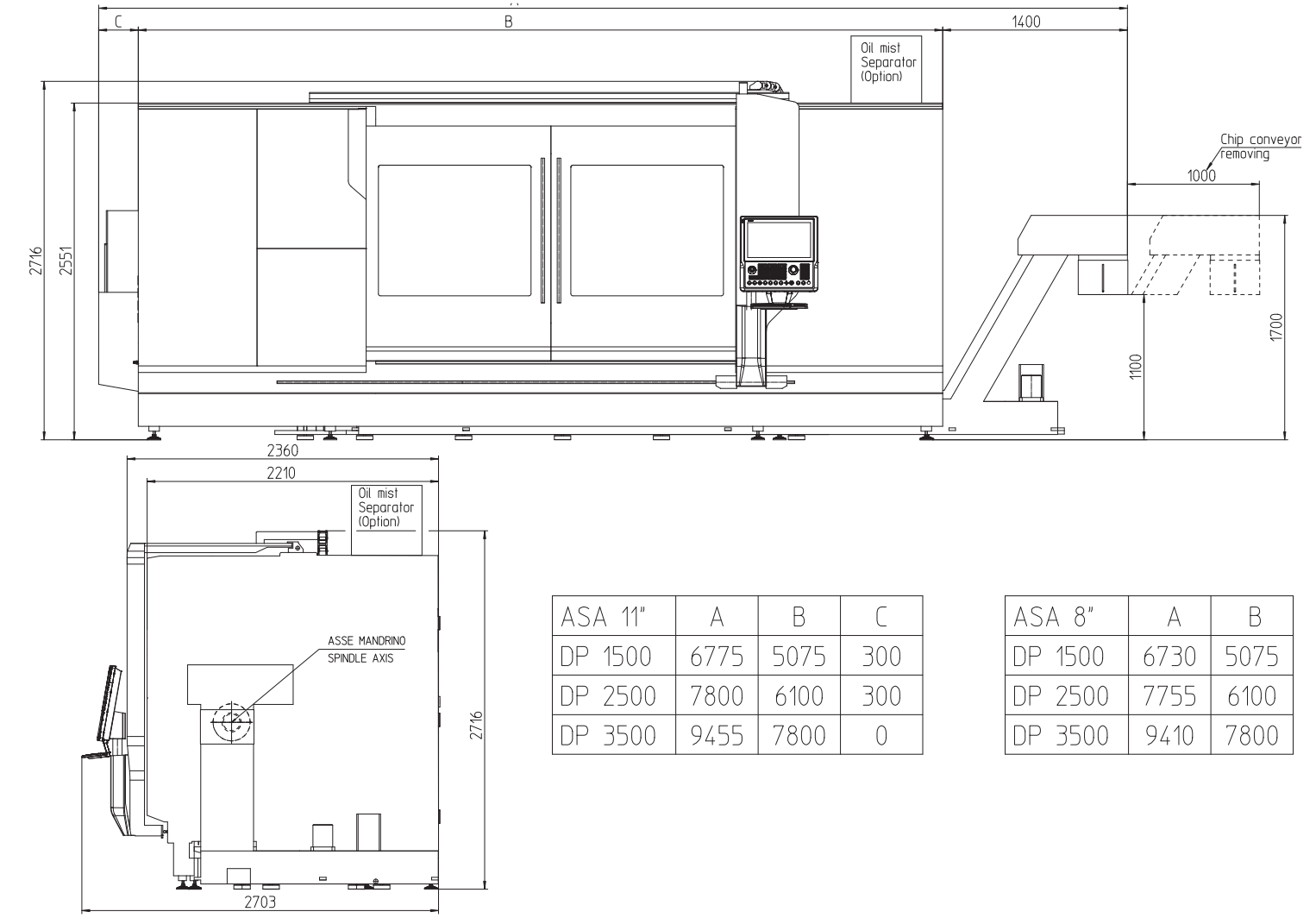

ASA 11"	A	B	C
DP 1500	6775	5075	300
DP 2500	7800	6100	300
DP 3500	9455	7800	0

ASA 8"	A	B
DP 1500	6730	5075
DP 2500	7755	6100
DP 3500	9410	7800

Indications in millimeters

WORK AREA

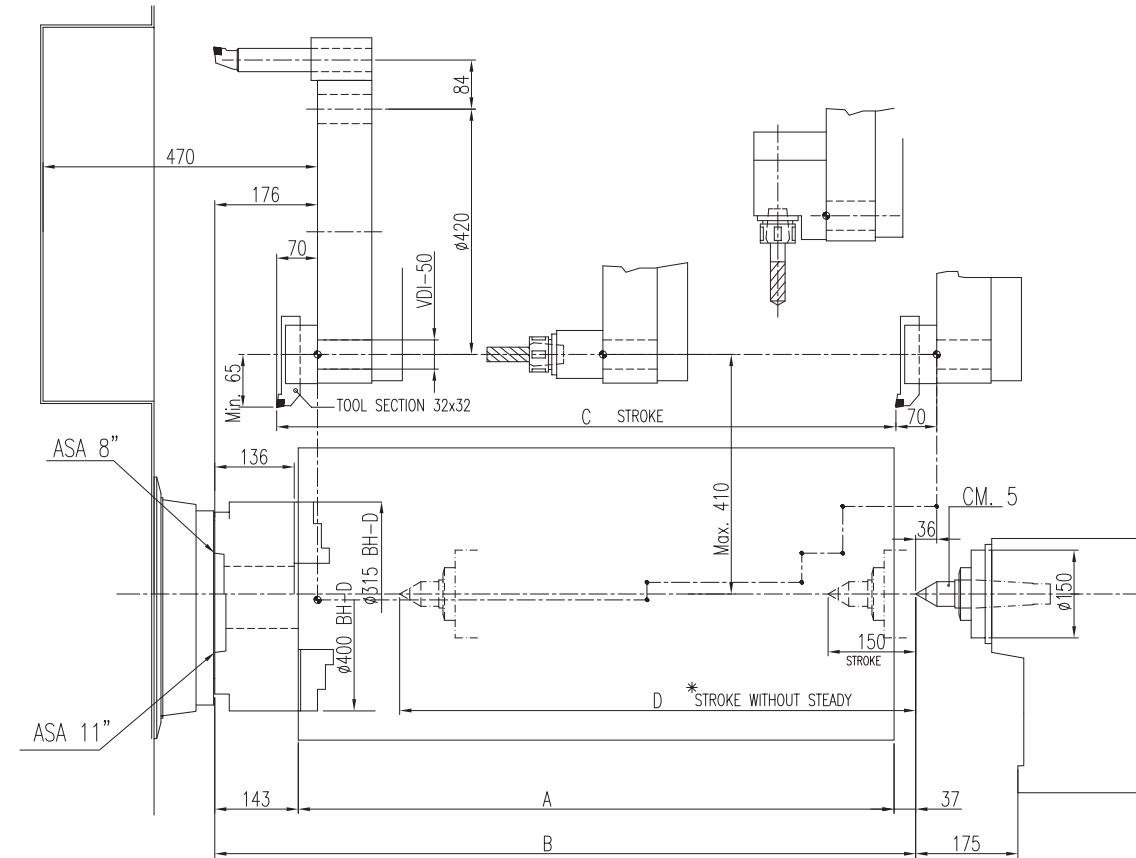

Indications in millimeters

WORK AREA

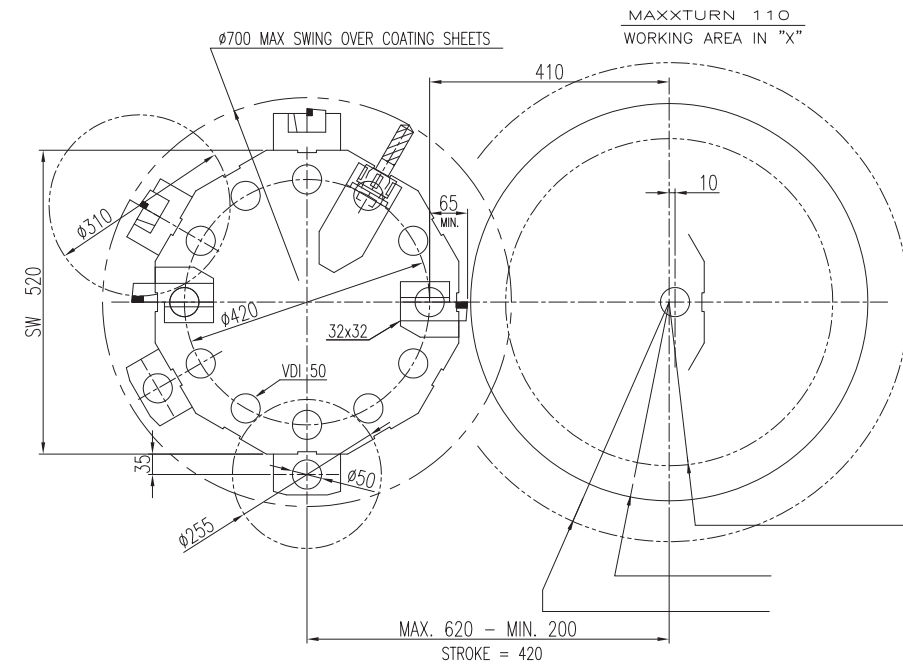

Indications in millimeters

TAILSTOCK WITH QUILL CM5

D.P.	A	B	C	D *
1500	1520	1700	1560	1300
2500	2520	2700	2560	2300
3500	3520	3700	3560	3300

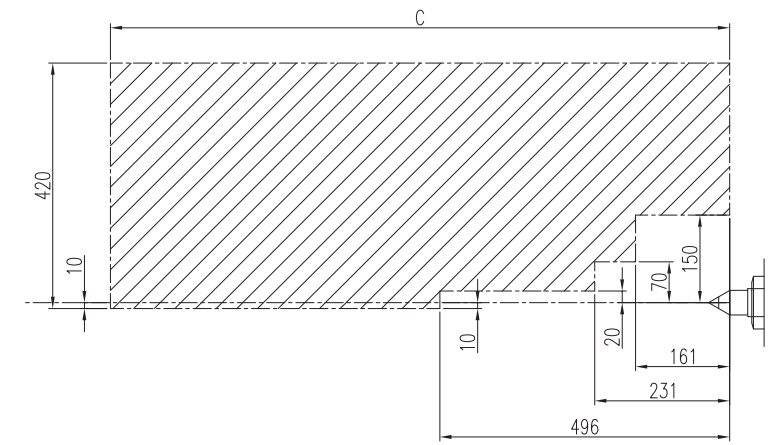

TECHNICAL DATA

Work area

Swing over bed	Ø 820 mm
Swing over cross slide	Ø 560 mm
Distance between centers	1700 / 2700 / 3700 mm
Maximum turning diameter	Ø 680 mm
Maximum part length	1500 / 2500 / 3500 mm

Travel

Travel in X	420 mm
Travel in Z	1560 / 2560 / 3560 mm
Travel in Y	-80 / +100 mm

Main spindle A2-8" (integrated spindle motor ISM)

Speed range	0 – 3500 rpm
Integrated spindle motor, power (100/40% DC)	33 kW
Torque (100/40% DC)	800 Nm
Spindle nose according to DIN 55026	A2-8"
Spindle bore	106 mm
Spindle bearing (inside diameter front)	160 mm
Max. chuck size	315 (400) mm

C-Axis on spindle A2-8"

Resolution	0,001°
------------	--------

Motor, Main spindle A2-11" (ZF-gear box)

Speed range (two step gear box)	0 – 2500 rpm
Power	52 kW
Torque	2480 Nm
Spindle nose according to DIN 55026	A2-11"
Spindle bore	125 mm
Spindle bearing (inside diameter front)	190 mm
Max. chuck size	400 (630) mm

Motor, Main spindle A2-15" (ZF-gear box)

Speed range (two step gear box)	0 – 2000 rpm
Power	52 kW
Torque	3410 Nm
Spindle nose according to DIN 55026	A2-15"
Spindle bore	125 mm
Spindle bearing (inside diameter front)	190 mm
Max. chuck size	500 (800) mm

C-Axis on spindle A2-11" – A12-15" (Automatic engaged, free from backlash)

Max. torque	2000 Nm
Resolution	0,005°

Tool turret (standard)

Number of tools stations (all driven)	12
VDI shaft DIN 69880	50 mm
Tool cross-section for square tools	32 x 32 mm
Shank diameter for boring bars	50 mm
Additional tools (block-tool)	12

Tool turret

Speed range	0 – 4000 rpm
Power	max. 16 kW
Torque	max. 66 Nm

Tool turret with direct drive system

Number of tools positions (all driven)	12
Precision-interface	BMT-65P
Tool holder for shanks	25 x 25 (32 x 32) mm
Tool holder for boring bars	50 (60) mm
Speed range	0 – 6000 rpm
Max. power	15 / 22 kW
Max. torque	45 / 62 Nm

Feed drive

Rapid motion speed X / Z / Y	24 / 30 / 12 m/min
Feed force in the X axis	17000 N
Feed force in the Z-axis	20000 N
Feed force in the Y-axis	17000 N

Tailstock with quill

Quill travel	150 mm
Quill diameter	150 mm
Max. application force	22200 N
Internal cone	MT 5

Coolant system (integrated in chip conveyor)

Tank capacity BL 1500 / 2500 / 3500	400 / 450 / 500 liter
Pump power 7 bar (option 8 bar)	1,15 kW

Power consumption

Connected load (spindle A2-8" / A2-11")	46 / 70 kVA
---	-------------

Dimensions

Height of centers above floor	1260 mm
Total height	2805 mm
Dimensions W x D BL 1500 / 2500 / 3500	6780 / 7800 / 9200 x 2530 mm
Total weight with chip conveyor BL 1500 / 2500 / 3500	ca. 16 / 18 / 20 t

beyond standard /

EMCO GmbH / Salzburger Str. 80 / 5400 Hallein-Taxach / Austria / T +43 6245891-0 / F +43 624586965 / info@emco.at

www.emco-world.com