

# Complete machining with HYPERTURN 665, ESPRIT and CPS



HYPERTURN 665 Powermill with LM1200 bar loader.

## Wintersteller

The Salzburg based supply company GMT Wintersteller GmbH shapes metal to order at four closely situated sites. This involves anything from steel construction for hydraulic engineering, forging, fabrication, welding, CNC-pipe bending and automated sawing. The company was founded in 1991.

165 employees.

Revenue: EUR 21m

**GMT**  
Wintersteller GmbH

GMT Wintersteller GmbH  
Leitenhaus 40  
5524 Annaberg  
Austria  
Tel: +43 6243 3838-0  
[www.gmt-metalltechnik.at](http://www.gmt-metalltechnik.at)

## Requirement profile

- Combined turning/milling center for complete machining
- Turnkey solution
- Reduction of setup times
- Perfect cost/performance ratio

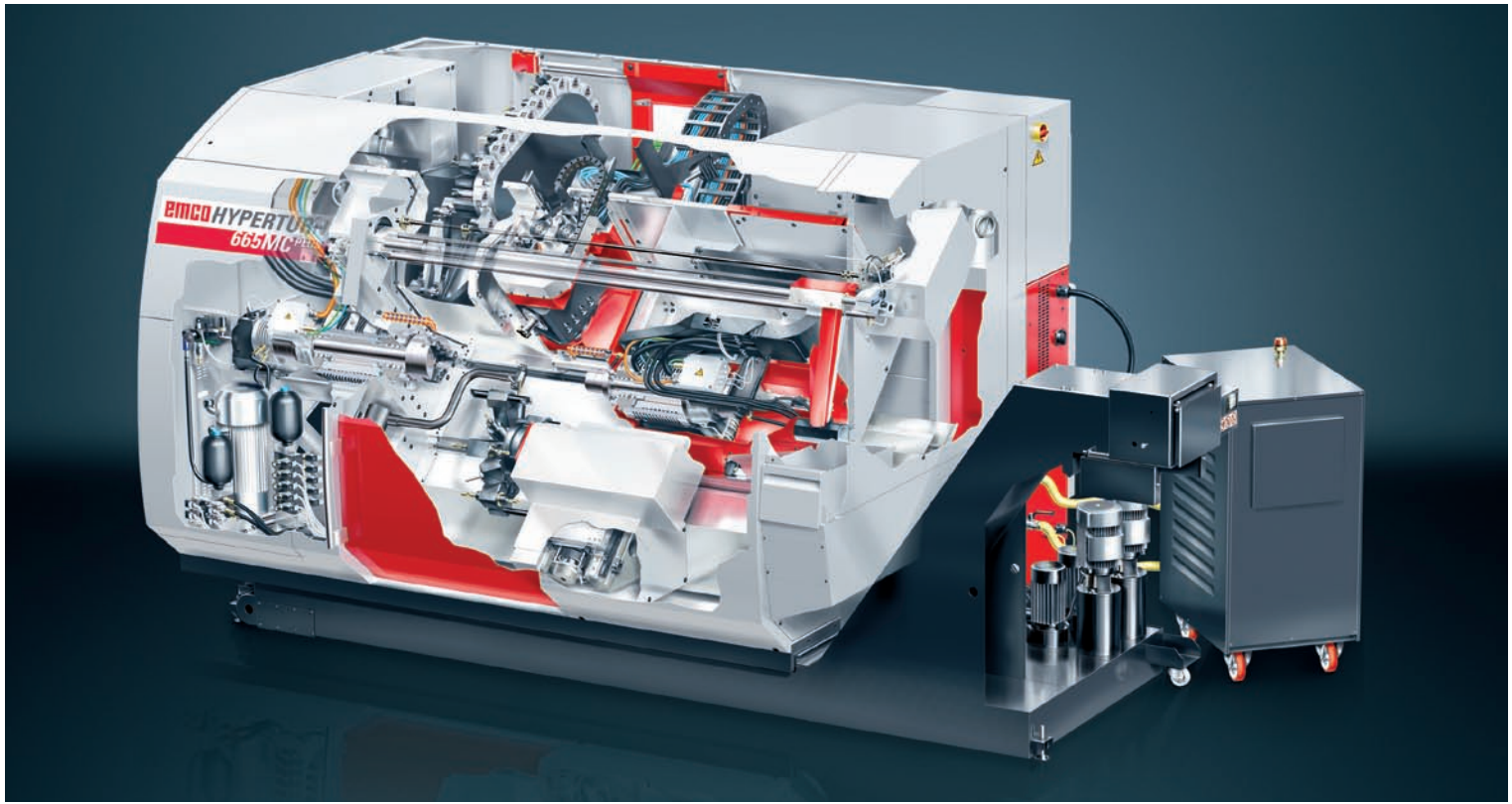

## A refinancing turbo for job shop production

The contract manufacturer GMT Wintersteller shapes metal with precision, guarantees in-house quality and delivers on schedule. To ensure favorable prices, the Salzburg company reduces unproductive times by clamping just once throughout the complete machining process and using a realistic external programming and simulation system. EMCO Hyperturn turning and milling center and the CAD/CAM system ESPRIT together with CPS Pilot as an offline software tool: Alone, each one boosts productivity - in combination, they transform your profits.

A visible trend in the supply industry is that customers are becoming increasingly demanding. Those wishing to offer a competitively wide range must work harder and fulfill higher quality demands and meet increasingly tighter delivery schedules. And at the same time, companies must be versatile, as customers prefer to have fewer but more reliable suppliers rather than a different contact partner for every individual problem.

The Salzburg based supply company GMT Wintersteller GmbH has realized this and has become one of the most important contract manufacturers in Salzburg. Metal is shaped to order at the four closely situated sites. This involves anything from steel construction for hydraulic engineering, forging, fabrication, and welding in Annaberg using CNC-lasers, plasma and flame cutting, CNC-pipe bending and automated sawing in Salzburg, and CNC turning and CNC milling using 3D-readings in Abtenau.

“Not only can we handle all materials here - from plastic to non-ferrous metals through to the demanding stainless materials”, says production programmer Josef Bendl, „ With our own quality assurance department we guarantee the correct result while managing to keep to tight time scales.“ Although there are still numerous conventional machines available among GMT Wintersteller’s extensive collection of machines, the trend within the company is towards complete machining using combined turning/milling centers.

„This also improves quality“, says Martin Schlager. The trained toolmaker has, like Josef Bendl, more than 10 years’ company experience and is likewise responsible for machine programming. „Our components are mostly highly complex, so every operation which we can avoid is a step towards higher levels of precision“. As an example, he displays a connecting flange, which can now be machined with just one clamping operation instead of the previous five. As well as achieving higher quality, the machining time is reduced by almost 50%, which is advantageous when keeping to delivery deadlines and reducing costs.

## EMCO Hyperturn 665 Powermill - a leap forward in productivity

The most recent investment in increased productivity using complete machining is an EMCO Hyperturn 665 Powermill fitted with a LM 1200 short bar loader and a discharge conveyer. It was only about a year ago that GMT Wintersteller saw this machine, which was quick to impress them. Instead of an upper turret, the Powermill’s B-axis is a milling spindle with a hollow shaft motor that can travel through 210°. A 24-tool (48-tool) magazine with a CAPTO C4 adapter is used as the tool holder. Among other things, the CAPTO tool clamping system’s exceptional stability is particularly impressive. When machining small dimensions, the completely distortion-free system ensures the highest possible precision by using multiple load transfer points and vibration elimination.

The GMT Wintersteller team know already from personal experience that the Hallein based quality manufacturer EMCO delivers a good cost/performance ratio. There were already using a number of EMCO CNC lathes and milling centers at their sites. „We knew we could rely on EMCO in terms of quality, manageability, and customer support, says Josef Pendl, who, among other things, greatly values and benefits from the close proximity of the manufacturer.

„Another reason for choosing the EMCO Hyperturn was to get everything from a single supplier, meaning that much of it comes pre-assembled,“ says Martin Schlager. „As a result, the machine’s mechanics are simple, it is solidly constructed, and is logical to operate“. After the initial operation at the beginning of December 2007 the machine has run continuously in intense, 24-hour operation every day without any problems.



„Using the convenient external programming, we were able to reduce the previous set up time for complex components from 8 to 12 hours to 2 to 3 hours,“ says Josef Pendl.



Josef Pendl, production programmer at GMT Wintersteller

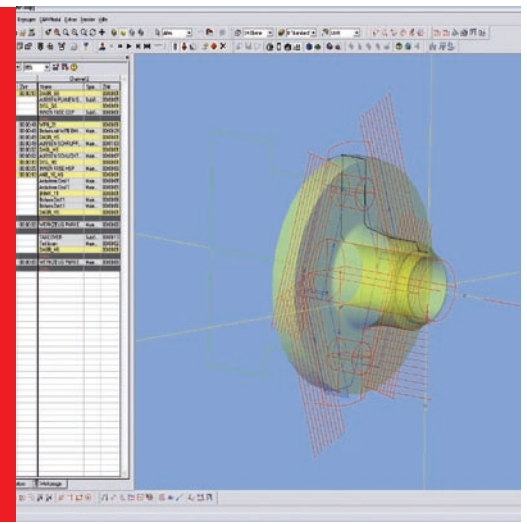

Customary direct machine programming gives way to convenient offline-programming on a laptop using ESPRIT from directly imported 3D-construction data.

### Method change with CPS Pilot and ESPRIT

The actual quantum leap is actually in the programming: Until GMT Wintersteller obtained the new machine, programming was usually carried out directly on the machine. By observing the Hyperturn 665, Josef Pendl and Martin Schlager got to know the offline-programming system CPS Pilot (Crash Prevention System), which at the time was something new.

This provides a virtual representation of the actual machine. In this system, the virtual Sinumerik NC core operates the simulation instead of the feed motors. Using this system, the operator can carry out a simulation exercise through an external computer terminal at any convenient location. The operator is presented with a realistic 3-D image of the machine and is able to plan, program, simulate and optimize a complete production run. The special feature of this is that, in contrast to programming and running at the machine itself, carrying out a complete simulation means that it is no longer necessary to stop the machine. At the same time, the machine can still be used productively for the production machining of components. This results in a reduction of up to 80% in set-up time and a significant increase in productivity and efficiency. Importantly the reliability of production is increased as collisions and very expensive damage to machines caused by them can be avoided.

GMT Wintersteller employees got to know ESPRIT in the same way. The universal CAD/CAM tool offers sophisticated methods of programming all machine tools. This includes the programming of 2-5 axis milling and boring machines, 2-22 axis turning and 2-5 axis wire eroding. In combination with the new EMCO Hyperturn Powermill, multi-tasking for lathe milling machines with B-axes is just as straightforward using the 3D-model method. „It was not hard to convince the boss that the extra version was worthwhile,“ Josef Pendl recalls. „He is very innovative and the potential savings using offline programming are tremendous“. Above all, this is because the vast majority of customers today provide their own 3-D data. „The direct import of manufacturing data from all

current 3D-CAD-systems in ESPRIT also eliminates errors, which otherwise could easily get overlooked when programming the machine directly“, as Martin Schlager describes a further useful software feature. „Furthermore, I can eliminate possible problems by simultaneously processing the two spindles and not have to waste money carrying out error runs on the machine.“

### A radical reduction in programming time.

As yet, both NC-programmers have only completed their basic training. However, using ESPRIT and CPS Pilot, they were still able to drastically reduce the time required for programming and setting up. „Using the convenient external programming, we were able to reduce the previous set up time for complex components from 8 to 12 hours to 2 to 3 hours,“ says Josef Pendl. „This comes very much into the calculations especially when small numbers of components are involved“.

The next step is clear: as ESPRIT is applicable to different machines of various manufactures and offers an extensive library of appropriate post processors, more and more machines should be converted to use this innovative and convenient offline simulation programming in order to further increase machine operating time. Martin Schlager is convinced that „as well as an increase in process reliability and an increase in the machine’s productivity, graphical programming means also that we are able to achieve greater volumes of output without an increase in machine setting personnel“ „We also get excellent engineering and software support from our turnkey supplier EMCO.“

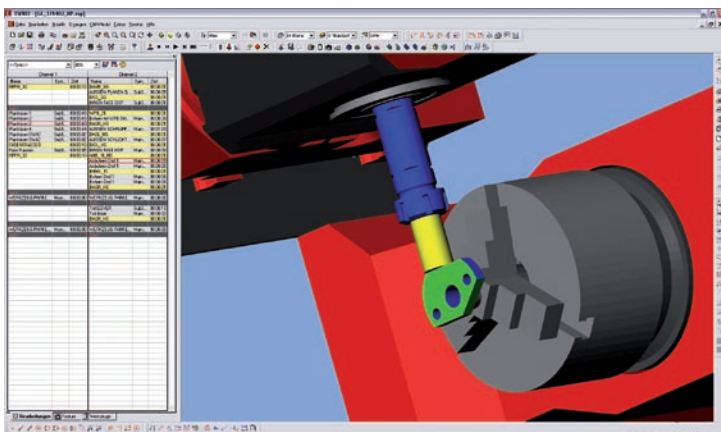

Simulation on the perfectly replicated virtual machine ...



The programmers and machine setters Josef Pendl and Martin Schlager – here showing a special tool holder manufactured in-house – decided on the EMCO Hyperturn 665 Powermill, but use offline-programming with ESPRIT and CPS Pilot to enter a more productive new world.

# [Technical data] EMCO HYPERTURN 665

Work area	
Swing over bed	600 mm (23.6")
Swing over slide	500 mm (19.7")
Distance between spindle noses	975 mm (38.4")
Max. turning diameter	430 mm (16.6")
Max. part length	744 mm (29.3")
Max. bar-stock diameter	65 (76,2) mm (2.6" (3"))
Travel	
Travel in X/X2	280/205 mm (11/8.1")
Travel in Z/Z2/Z3	900/750/750 mm (35.4/29.5/29.5")
Travel in Y	100 (+/-50) mm (3.9 ( +/-2"))
Main spindle	
Speed range (infinitely variable)	0 – 5000 (4000) rpm
Maximum torque	250 Nm (184.3 ft/lbs)
Spindle nose DIN 55026	A2-6 (A2-8)
Spindle diameter at front bearing	105 (130) mm (4.1" (5.1"))
Spindle bore (excluding draw pipe)	Ø 73 (86) mm (2.9" (3.4"))
Counter spindle	
Speed range (infinitely variable)	0 – 7000 rpm
Maximum torque	130 Nm (95.8 ft/lbs)
Spindle nose DIN 55026	A2-6
Spindle diameter at front bearing	Ø 73 (86) mm (2.9" (3.4"))
C axes	
Resolution	0,001°
Rapid traverse	1000 rpm
Drive power	
Main spindle (AC hollow-spindle motor)	29 kW (38.9 hp)
Counter spindle (AC hollow-spindle motor)	22 kW (29.5 hp)
Tool turret top and bottom	
Number of tool stations	2x12
VDI shaft (DIN 69880)	30 (40) mm (1.2" (1.6"))
Tool cross-section for square tools	20 x 20 (25 x 25) mm (0.8 x 0.8" (1 x 1"))
Shank diameter for boring bars	32 mm (1.3")
Turret indexing time	0,2 sec

Driven tools	
Speed range	0 – 5000 (4500) rpm
Max. torque	25 Nm (18.4 ft/lbs)
Drive power	6,7 kW (9 hp)
Number of driven tools	2 x 12
B-QuickMill (with tool turret)	
Travel range (with interpolation)	45°
Holding torque of indexing (5°)/clamping (0.001°)	3000/600 Nm (2211/442 ft/lbs)
B-PowerMill (with milling spindle)	
Travel range (with interpolation)	210°
Holding torque of indexing (5°)/positioning (0.001°)	3600/1300 Nm (2653/958 ft/lbs)
Number of tools	24/48
Tool holder	Capto C4 (HSK A50)
Maximum torque	40 Nm (29.5 ft/lbs)
Drive power	14,5 kW (19.4 hp)
Speed range	0 – 10000 rpm
Tool changing time (tool to tool)	1,3 sec
Feed drives	
Rapid motion speed in X/Z/Y/Z3 (counter spindle)	24/30/10/30 m/min (945/1181/394/1181 ipm)
Feed force in X/Z/Z3 (counter spindle)	5000/8000/9000 N (1124/1798/2023 lbs)
Coolant system	
Tank capacity	300 l (79 gal)
Pump power	2 x 2,2 kW (2.7 x 3 hp)
Power consumption	
Connected load	46 kVA
Compressed air	6 bar (87 PSI)
Dimensions	
Height of center above floor	1200 mm (47.2")
Total height	2300 mm (90.6")
Footprint (excluding chip conveyor) W x B	3400 x 2550 (133.9 x 100.4")
Total weight	ca. 9500 kg
Safety devices	to CE